

Anchors aweigh

Anchors aweigh is a sorting game in which children have to finish the pattern by moving the symbols to the right place. The rectangular wall game has a natural, modern frame made of birch plywood with a white painted front which compliments many environments.

Graphic colours Pantone no.



Play module | Anchors aweigh

Article no.	Frame colour	Colour code	Size HxWxD	Mounting	Age	KG	
PP00700	White	RAL 9003	70x45x4,5cm	wallmount	2 - 8 years	5,8 KG	MDF, Beechwood, ABS, RVS, Birch Plywood



TÜV SGS All our products are inspected, tested and certified by SGS and TÜV.

EN 71 European standard EN 71 specifies safety requirements for toys. Compliance with the standard is legally required for all toys sold in the European Union.

FSC All our products only use FSC certified wood, so eco- and environment friendly!

CE Our products are conform with health, safety and environmental protection standards for products sold within the EU.

IKC | HQ EUROPE
 Dronten | The Netherlands
 +31 (0)321 38 77 30
 sales@ikcplay.com
 www.ikcplay.com

IKC | HQ ASIA
 Shanghai | China
 +86 (0)573 82 58 61 83
 sales.cn@ikcplay.com
 www.ikcplay.com.cn

● Playable on one side

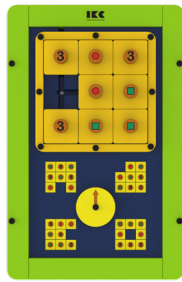
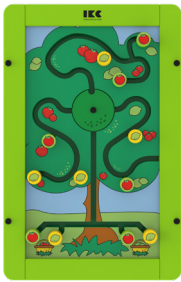
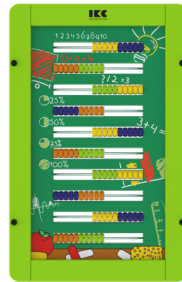

■ Playable on both sides

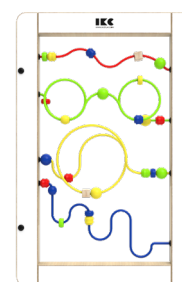
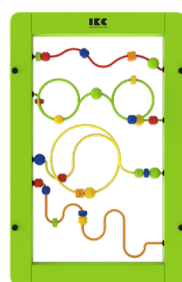

Play Module

■ PM^A

● PM^B

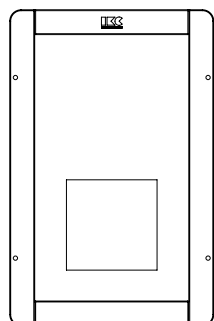

Playable on one side

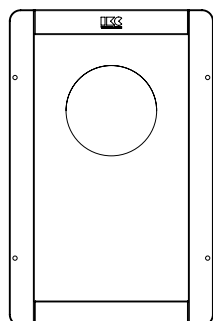

Playable on both sides

FM Frame

FM

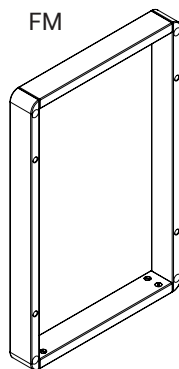

Required tools

Drill

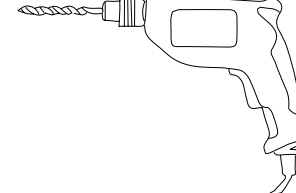

Fence mounted

FP^A

FP^B

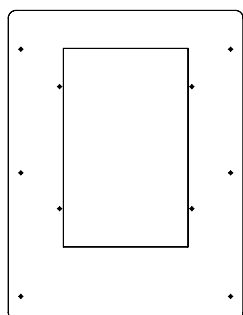
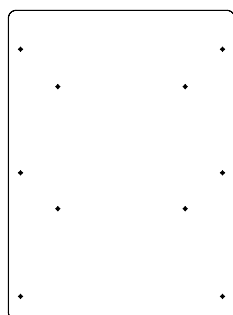

Playtower mounted

PP

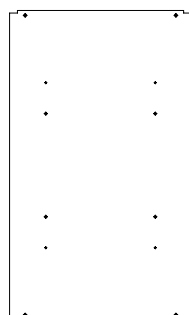

Play system mounted

PS

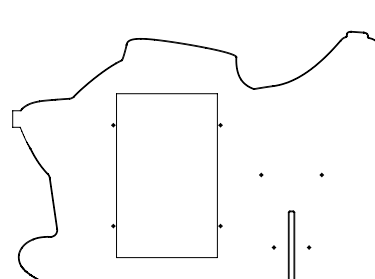

Play system of choice

Screws

S4

S9

S13

S16

S18

S19

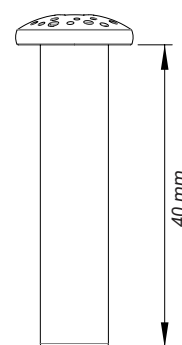
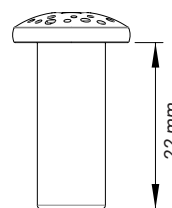
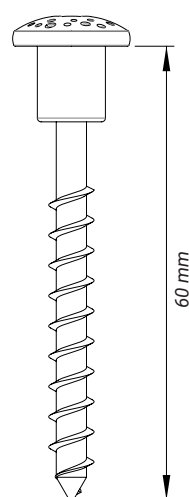
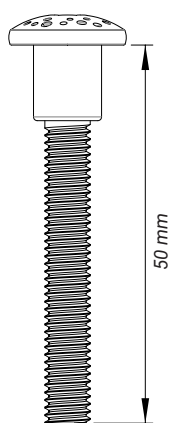
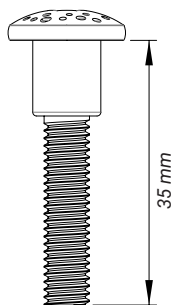
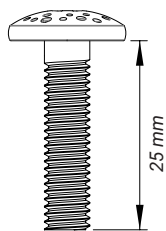

Play Module ■ PM^A ● PM^B

All the play modules need to be mounted 40 cm above the ground. This is for the optimum play comfort.

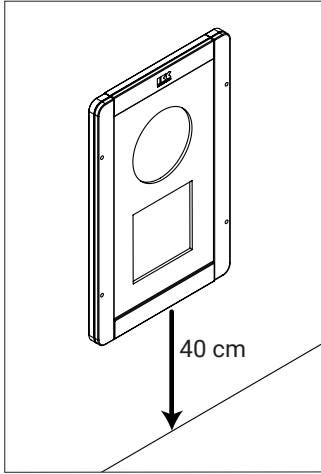

1.1 Play Module

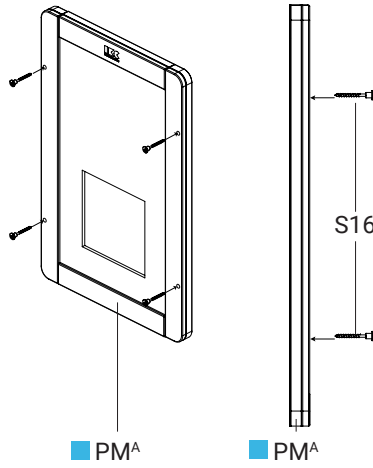

Required tools

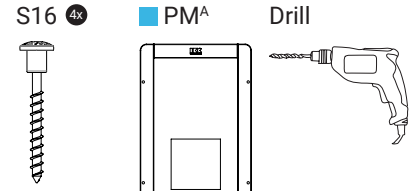

2.1 Play Module with FM Frame ● PM^B

To put a play module on a FM frame, you should remove these slats.

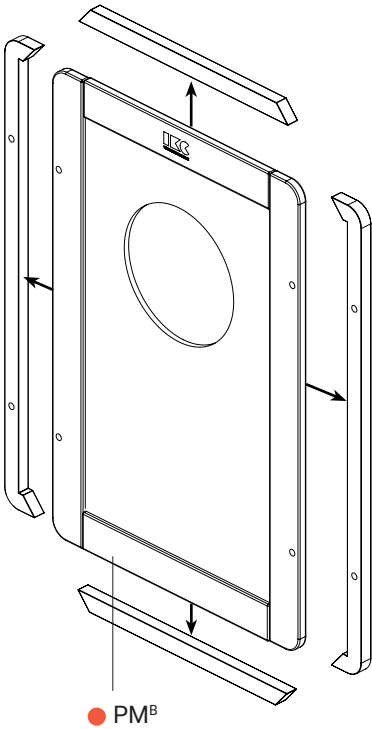

2.2 Play Module install FM Frame ● PM^B

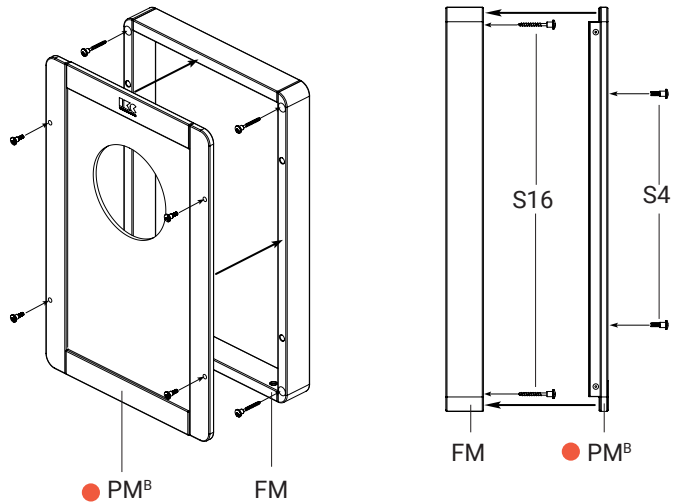
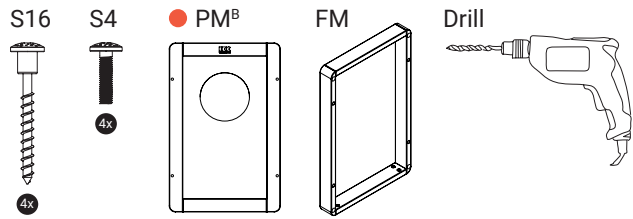

3.1 Play module ■ PM^A ● PM^B

To put a play module on a playsystem, you should remove these slats.

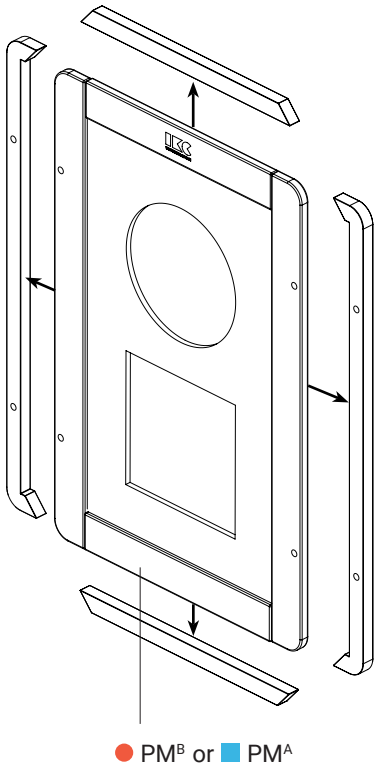

3.2 Play module on play system

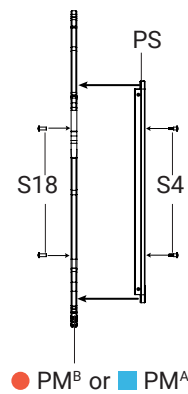
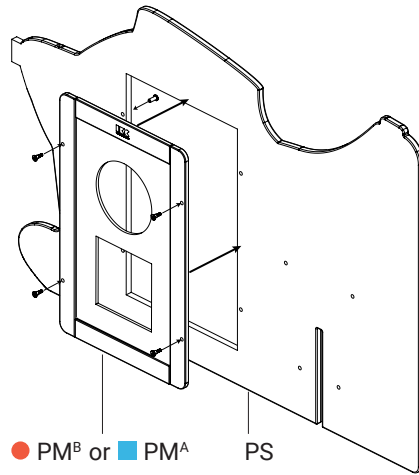

Required tools

● PM^B or ■ PM^A

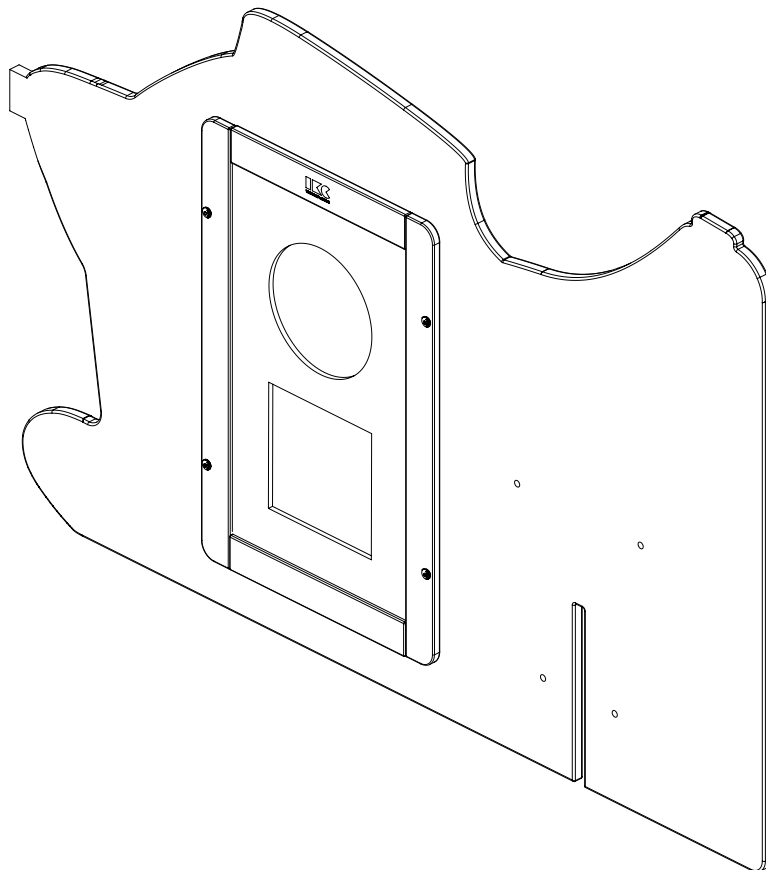
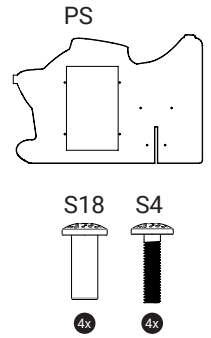

Play module ■ PM^A ● PM^B

All the play modules needs to be mounted 40 cm above the ground. This is for the optimum play comfort.

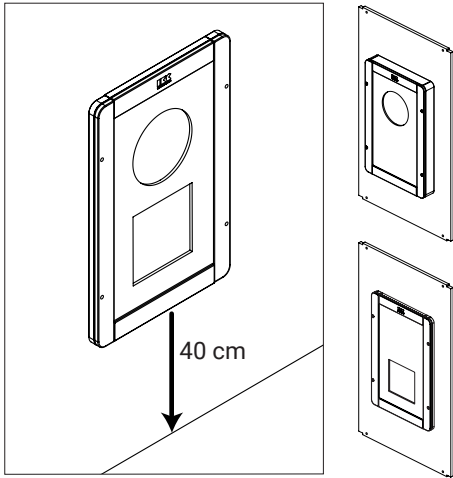

4.1 Install play module on play tower

Required tools

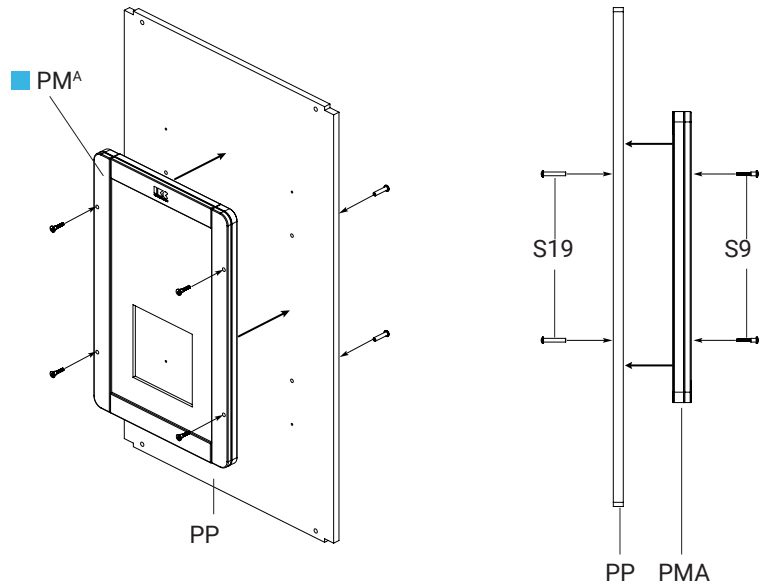
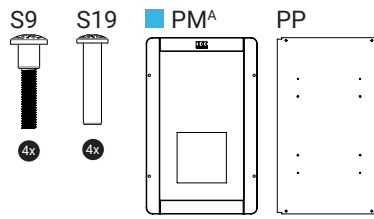

5.1 Install FM Frame to play module ● PM^B

To put a playmodule on a FM frame, you should remove these slats.

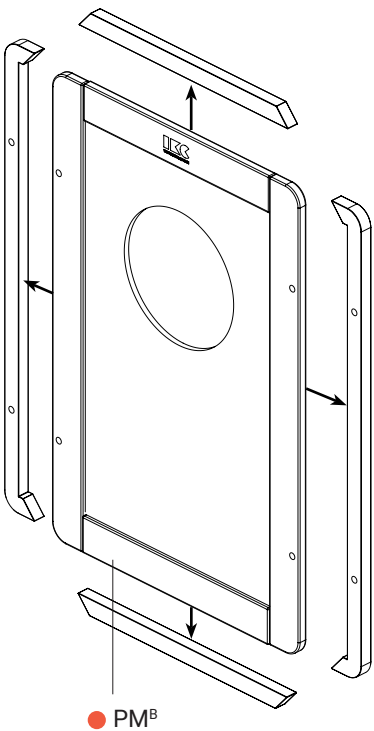

5.2 Install play module with FM frame on play tower

Required tools

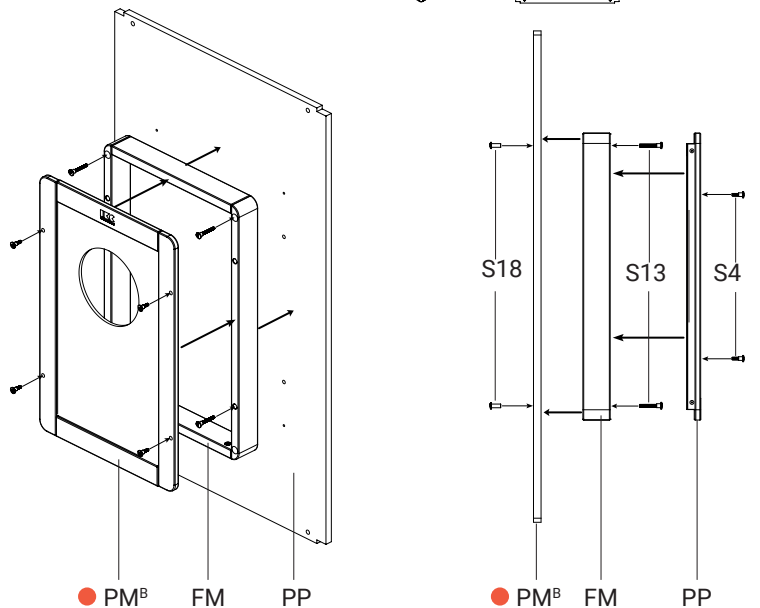
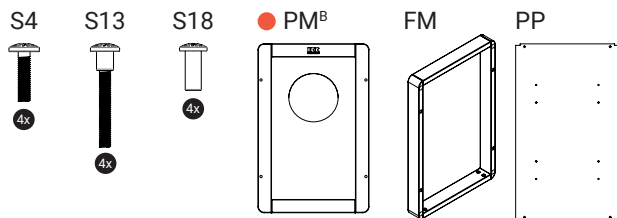

Play module ■ PM^A ● PM^B

All the play modules needs to be mounted 40 cm above the ground. This is for the optimum play comfort.

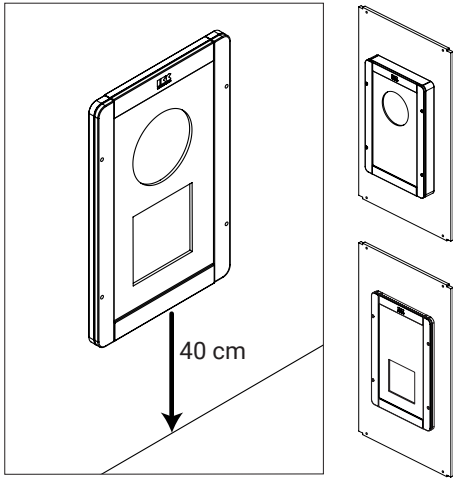

6.1 Install play module on fence

Required tools

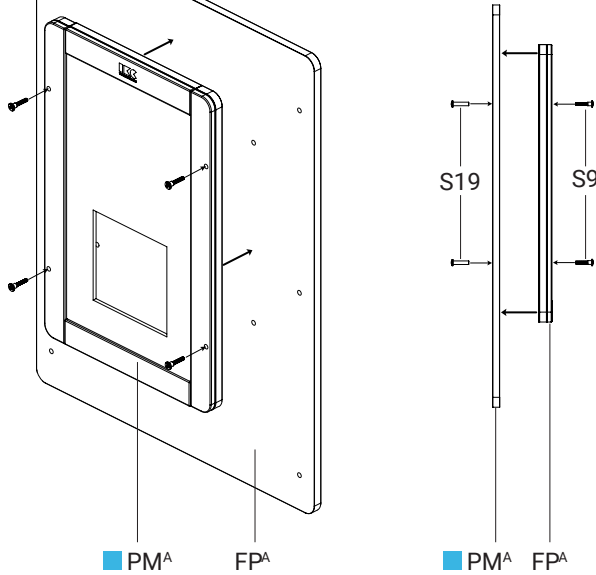
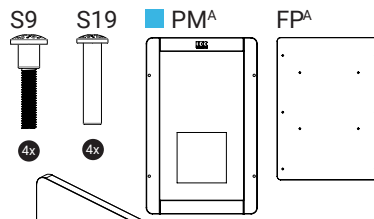

7.1 Install FM Frame to play module ● PM^B

To put a playmodule on a FM frame, you should remove these slats.

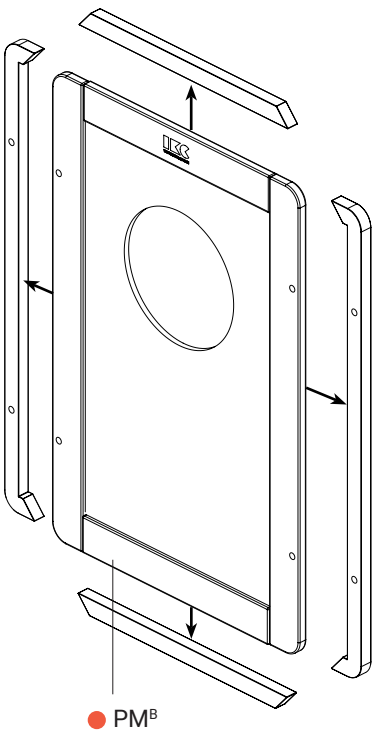

7.2 Install play module with FM frame on fence

Required tools

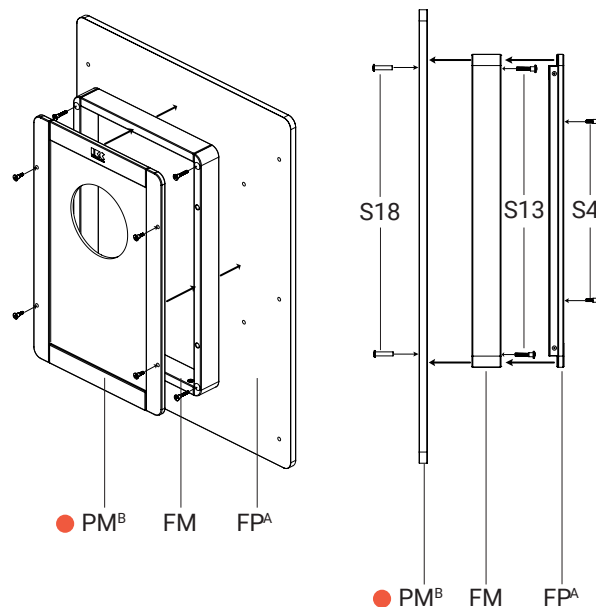
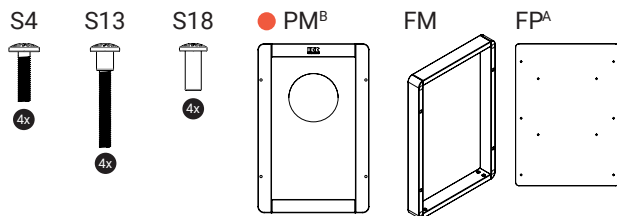

8.1 Remove the slats ● PM^B ■ PM^A

To put a playmodule on a fence (FP^B), you should remove these slats.

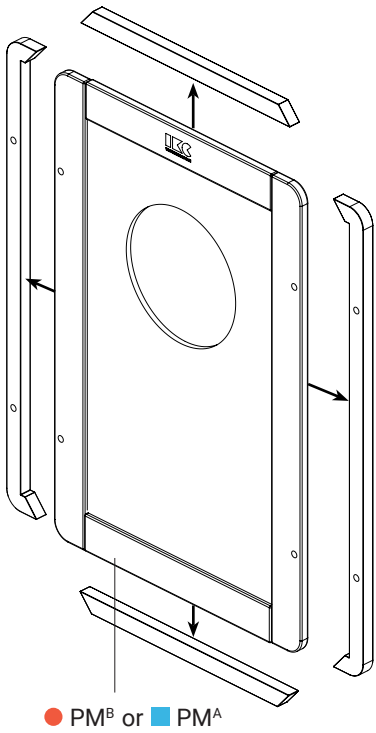

8.2 Install play module on fence
Required tools

